



FLEX  
SERIES

# USER MANUAL



FLEX-M

FLEX G-36

FLEX-PLUS

FLEX-S

FLEX-DARK

FLEX-S-DARK





# TABLE OF CONTENT

- INTRODUCTION ..... 3**
  - Thank you for choosing SPYPOINT..... 3
  - Contact us..... 3
  - About us..... 3
  - Join the SPYPOINT community..... 3
- COMPONENTS..... 4**
- FEATURES..... 6**
- POWER SUPPLY..... 7**
  - Special instructions for the FLEX-S and FLEX-S-DARK..... 7
  - Choosing a power supply ..... 7
  - AA batteries ..... 8
  - LIT-22 rechargeable lithium battery pack..... 8
  - SPLB-10 or SPLB-22 solar panel and lithium battery  
combo unit..... 8
  - Battery usage and power supply combinations..... 9
  - How to check battery level..... 9
- MICROSD MEMORY CARD..... 10**
  - Installation..... 10
  - Formatting..... 11
  - Removal..... 11
  - Transferring files to a computer..... 12
- ANTENNA ..... 13**
  - Install the antenna..... 13
- ACTIVATION ..... 14**
  - Find the activation code..... 14
  - Camera activation for new users ..... 14
  - Camera activation for existing users on the  
SPYPOINT app ..... 15
  - Camera activation for existing users on the  
SPYPOINT website ..... 15
  - Choose a transmission plan ..... 15
- FIELD INSTALLATION..... 16**
  - Install the camera in the field ..... 16
  - Start the camera ..... 16
  - Initiate the first-time start-up sequence..... 17
  - Take a TEST photo ..... 17
- CONFIGURATION ..... 18**
  - Manage device..... 18
  - Image capture ..... 18
  - Cellular settings..... 19
  - Camera commands ..... 19
  - General ..... 20
- CAMERA STATUS ..... 21**
  - Verifying camera status ..... 21
  - Notifications..... 21
  - Status page ..... 21
  - STATUS lights ..... 22
- OFFERED ACCESSORIES ..... 23**
- TROUBLESHOOTING ..... 24**
- SPYPOINT WARRANTY ..... 26**
- REGULATORY COMPLIANCE..... 27**
  - FCC statement..... 27
  - CE statement ..... 27
  - IC statement..... 27
  - Frequency..... 28
- DISPOSAL ..... 29**

## THANK YOU FOR CHOOSING SPYPOINT

Congratulations! You're about to start an exciting journey with your new FLEX series cellular trail camera. Designed to be reliable, tough, and easy to use, the FLEX series makes it simple to start receiving photos and videos straight from the field to the SPYPOINT app on your phone.

This user manual will guide you through everything you need to know to set up, activate, and install your FLEX series camera. Whether it's your first trail camera or a new addition to a growing collection, you'll have all the information you need to make the most of it with confidence.

Thank you for choosing SPYPOINT. A whole new level of scouting is waiting for you – let's get started!

## CONTACT US

**If you have any questions or need support, here is how to contact us:**





1. Visit our support page at [www.spypoint.com/en/support](http://www.spypoint.com/en/support) for answers to frequently asked questions.
2. For **24/7** assistance, please use the chat service on [www.spypoint.com](http://www.spypoint.com). Start a chat by clicking on the **"CHAT NOW"** button in the lower righthand corner of the page.
3. Contact us by telephone at **1-888-779-7646**. Our service office hours change by season. For current hours, please visit [www.spypoint.com/en/contact-us](http://www.spypoint.com/en/contact-us).

## ABOUT US

SPYPOINT began as a small start-up in 2004, and it didn't take long for us to change the game. By 2012, we helped revolutionize hunting with cellular trail cameras, giving hunters a way to stay connected to the outdoors anytime, anywhere. Since then, we've transmitted more than 250 M photos and we continue to lead the way in trail camera innovation, ensuring our users have the most reliable tools to stay ahead of the game.

---

## JOIN THE SPYPOINT COMMUNITY

-  [www.facebook.com/SPYPOINT](http://www.facebook.com/SPYPOINT)
-  [www.twitter.com/SPYPOINTcamera](http://www.twitter.com/SPYPOINTcamera)
-  [www.youtube.com/SPYPOINTtrailcam](http://www.youtube.com/SPYPOINTtrailcam)
-  [www.instagram.com/spypointcamera](http://www.instagram.com/spypointcamera)
-  [www.tiktok.com/@spypointcamera](http://www.tiktok.com/@spypointcamera)

# COMPONENTS

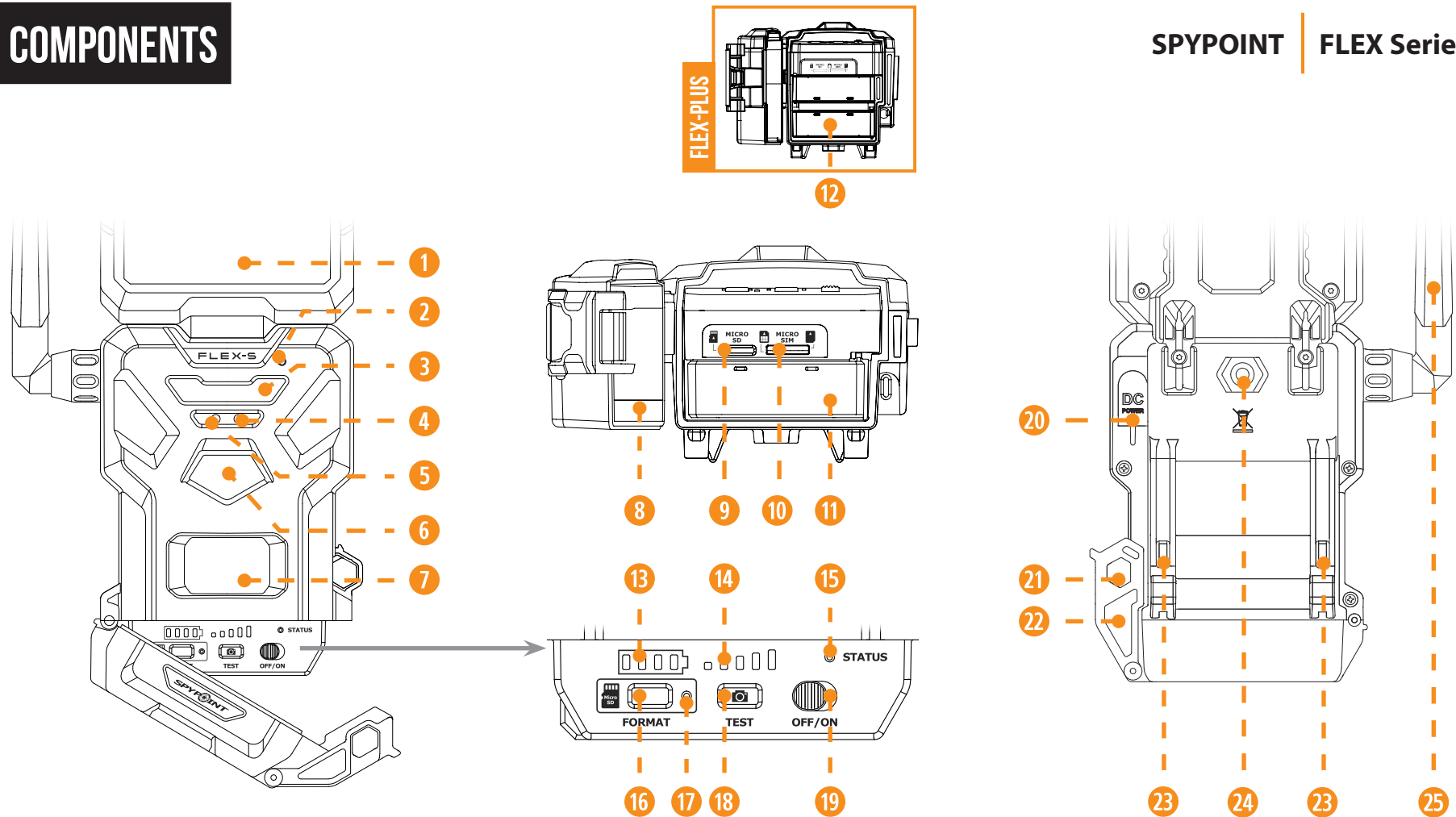

- |   |  |                  |  |
|---|--|------------------|--|
| 1 Solar panel<br><b>FLEX-S &amp; FLEX-S-DARK only</b> | 7 Detection lens                                   | 13 Battery level | 20 12 V jack   |
| 2 Microphone  | 8 Battery door                                     | 14 Signal level  | 21 Cable lock hole                                   |
| 3 IR LED  | 9 microSD card slot                                | 15 STATUS light  | 22 Locking latch                                     |
| 4 Light sensor  | 10 Micro SIM card slots                            | 16 FORMAT button | 23 Slots for installation strap                      |
| 5 Delay light   | 11 Battery tray                                    | 17 FORMAT LED    | 24 Screw-thread for standard<br>1/4"-20 tripod mount |
| 6 Photo lens  | 12 Secondary battery tray<br><b>FLEX-PLUS only</b> | 18 TEST button   | 25 Antenna   |
|   |  | 19 OFF/ON switch |  |

- 1 SOLAR PANEL (FLEX-S & FLEX-S-DARK only)**  
Solar energy sensor for charging the internal lithium battery.
- 2 MICROPHONE**  
Records sound in video mode.
- 3 IR LED**  
2 powerful LEDs that illuminate at night for clear black and white photos and videos.
- 4 LIGHT SENSOR**  
Detects the ambient lighting conditions for taking photos and videos: in colors during the day, black and white at night.
- 5 DELAY LIGHT**  
During installation, once the signal is found, this light flashes for 20 seconds to allow the user to walk away without being captured.
- 6 PHOTO LENS**  
Image sensor.
- 7 DETECTION LENS**  
Enlarges the detection area of the camera's motion sensor.
- BATTERY DOOR**  
Provides access to the battery compartment, microSD card, STATUS light, and OFF/ON switch.
- 9 microSD CARD SLOT**  
Space to insert the microSD card (not included) needed to save photos and videos.
- MICRO SIM CARD SLOTS**  
Space to insert two SIM cards. It is necessary to activate cellular functions. The SIM cards, pre-installed and preactivated, are included with the camera. It is important to use a SPYPOINT SIM cards (supplied by SPYPOINT), otherwise the cellular functions of the camera will be inoperative.
- 11 BATTERY TRAY**  
Removable device in which the 8 alkaline or lithium AA non-rechargeable batteries are inserted (not included with the camera).
- 12 SECONDARY BATTERY TRAY (FLEX-PLUS only)**  
Removable device in which the 8 alkaline or lithium AA non-rechargeable batteries are inserted (not included with the camera).
- 13 BATTERY LEVEL**  
During startup, the camera will illuminate the number of lights corresponding with the current battery level of the camera.
- 14 SIGNAL LEVEL**  
During startup, the camera will illuminate the number of lights corresponding with the signal level. 5 bars being excellent and 1 bar being poor.
- 15 STATUS LIGHT**  
During installation, it flashes to indicate to the user the strength of the cellular signal. During regular operation, it indicates that the camera is recording or transferring files.
- 16 FORMAT BUTTON**  
This button will allow you to format the microSD card during the start up of the device.
- 17 FORMAT LED**  
The LED will flash while the SD card is being formatted and turn solid once complete.
- 18 TEST BUTTON**  
This button will allow you to send a photo to your app (if you have a transmission plan with remaining photos).
- 19 OFF/ON SWITCH**  
Allows the user to turn the camera OFF/ON.
- 20 12 V JACK**  
Allows you to insert a power cord connected to an external 12 V source.
- 21 CABLE LOCK HOLE**  
Allows you to install a #CLM-6FT padlock cable to secure the unit (sold separately).
- 22 LOCKING LATCH**  
Allows you to lock, unlock and open the door.
- 23 SLOTS FOR INSTALLATION STRAP**  
Allows the camera to be installed using the included installation strap.
- 24 SCREW-THREAD FOR STANDARD ¼"-20 TRIPOD MOUNT**  
Allows you to attach a standard tripod ¼"-20.
- 25 ANTENNA**  
Captures the cellular signal.

# FEATURES

	FLEX-M	FLEX G-36/ FLEX G-36C	FLEX-PLUS	FLEX-S	FLEX-DARK	FLEX-S-DARK
<b>Network</b>	MULTI-CARRIER LTE AUTO-CONNECTIVITY					
<b>Photo resolution</b>	28 MP	36 MP	36 MP	36 MP	40 MP	40 MP
<b>Photo file format</b>	JPEG					
<b>Time-lapse</b>	✓	✓	✓	✓	✓	✓
<b>Time-lapse +</b>	✓	✓	✓	✓	✓	✓
<b>Multi-shot mode</b>	Up to 3					
<b>Capture mode</b>	Color photo/video by day   Black & white photo/video by night					
<b>Video resolution</b>	720p	1080p	1080p	1080p	1080p	1080p
<b>Video file format</b>	MP4					
<b>Video length</b>	15 s					
<b>Audio recording</b>	✓	✓	✓	✓	✓	✓
<b>External memory</b>	Up to 512 GB					
<b>Internal power</b>	-	-	-	✓	-	✓
<b>AA batteries (NR)</b>	8	8	8 or 16	8	8	8
<b>Lithium battery pack</b>	1 X LIT-22	1 X LIT-22	1 or 2 X LIT-22	1 X LIT-22	1 X LIT-22	1 X LIT-22
<b>External power source</b>	12 V power (SPLB-22, SPLB-10)					
<b>Movement detector</b>	Infrared					
<b>Detection angle</b>	40°					
<b>Detection range</b>	90 ft / 27 m	100 ft / 30 m	100 ft / 30 m	100 ft / 30 m	100 ft / 30 m	100 ft / 30 m
<b>Trigger speed</b>	0.4 s	0.3 s	0.3 s	0.3 s	0.3 s	0.3 s
<b>Motion delay</b>	Adjustable from Instant to 1 hour					
<b>LEDs</b>	2 powerful 850 nm low glow LEDs				2 powerful 850 nm low glow LEDs and 2 powerful 940 nm no glow LEDs	
<b>Night range</b>	90 ft / 27 m	100 ft / 30 m	100 ft / 30 m	100 ft / 30 m	100 ft / 30 m	100 ft / 30 m
<b>Physical dimensions</b>	3.93" (W) x 3.15" (D) x 5.1" (H) / 9.98 cm (W) x 8 cm (D) x 12.95 cm (H)	3.93" (W) x 3.15" (D) x 5.1" (H) / 9.98 cm (W) x 8 cm (D) x 12.95 cm (H)	3.94" (W) x 4.34" (D) x 5.5" (H) / 10.01 cm (W) x 11.02 cm (D) x 13.97 cm (H)	3.93" (W) x 3.15" (D) x 8.7" (H) / 9.98 cm (W) x 8 cm (D) x 22.10 cm (H)	3.93" (W) x 3.15" (D) x 5.1" (H) / 9.98 cm (W) x 8 cm (D) x 12.95 cm (H)	3.93" (W) x 3.15" (D) x 8.7" (H) / 9.98 cm (W) x 8 cm (D) x 22.10 cm (H)
<b>Temperature</b>	Operating: -30 °C to 50 °C (-22 °F to 131 °F)   Storage: -40 °C to 60 °C (-40 °F to 140 °F)					



## SPECIAL INSTRUCTIONS FOR THE FLEX-S AND FLEX-S-DARK



**IMPORTANT: before first use, fully charge the internal battery**

- Ensure the camera is powered OFF.
- Connect the camera to the included 12 V DC charging cable.
- The STATUS light will illuminate red while charging and turn OFF when fully charged.
- Please keep in mind that the function of the solar panel is to maintain the charge of the internal battery or to slowly charge it. It will be effective as soon as sunlight is detected.
- Under optimal conditions (a configuration that consumes little energy and a sunny environment), the camera's internal battery can maintain a consistent charge for up to 11 months.
- It's not required to add back up AA batteries or a LIT-22 to the FLEX-S or FLEX-S-DARK, but you may want to in case the solar panel cannot charge the internal battery quickly enough. If it runs out, the camera will shut down unless you have a secondary power source (e.g.: LIT-22, AA, 12 V, etc.). In the event the internal battery is depleted, the camera will first default to the 12 V, then to the LIT-22 or AAs installed in the battery tray.
- If the camera turns OFF, the solar panel will continue to charge the internal battery. For a quicker recharge, connect the camera to a wall outlet using the supplied 12 V DC charging cable and a USB power adapter (sold separately). After recharging the internal battery, the camera will return to the settings you previously selected. It will need to be manually turned back on using the OFF/ON switch.
- Please keep the solar panel clear of any objects or elements that may prevent it from working optimally (e.g.: snow). If it is partially covered, it will still work, but to a limited extent.

## CHOOSING A POWER SUPPLY

**There are four power options compatible with your FLEX series camera:**

- Standard alkaline or lithium AA batteries
  - Rechargeable 12 V battery
  - LIT-22 rechargeable lithium battery pack
  - SPLB-10 or SPLB-22 solar panel with lithium battery
-

### AA BATTERIES

#### INSTALLATION:

- Unlock the camera latch and open the battery door.
- Insert the AA batteries into the battery tray following polarity (+) and (-) indications.
- Slide the battery tray back into the battery compartment with arrows facing up (see photo).

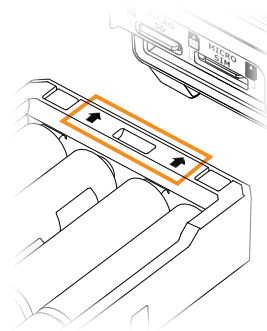

#### TIPS FOR BEST RESULTS WITH AA BATTERIES:

- Do not mix new and old batteries, batteries of different brands or batteries of different types. In this situation, some batteries may be over-discharged due to a difference in voltage or capacity. This can result in venting, leakage, or rupture and may cause personal injury.
- Always purchase the correct size and grade of battery most suitable for the intended use.
- Replace all batteries in a set at the same time.
- Clean the battery contacts and those of the device prior to battery installation.
- Ensure that the batteries are installed correctly according to the polarity indicators (+ and -).
- Always remove batteries from equipment that will not be in use for an extended period.
- Remove used batteries promptly.
- Do not use rechargeable AA batteries (their lower voltage will generate operational issues).

### LIT-22 RECHARGEABLE LITHIUM BATTERY PACK

Replaces up to 1000 standard AA batteries.



REPLACES UP TO  
**1,000**  
AA BATTERIES

### SPLB-10 OR SPLB-22 SOLAR PANEL AND LITHIUM BATTERY COMBO UNIT

- Combines a solar panel and lithium battery into one unit to reduce wires and setup time.
- Plugs directly into the camera to provide extensive, ongoing battery life.
- **SPLB-10:** replaces up to 1,000 AA batteries and can provide power for up to 6 months at a time, even when the panel is not exposed to direct sunlight.
- **SPLB-22:** replaces up to 2,000 AA batteries and can provide power for up to 12 months at a time, even when the panel is not exposed to direct sunlight.
- Additional jacks and plugs allow for device flexibility (SPLB-22 only).





### BATTERY USAGE AND POWER SUPPLY COMBINATIONS

- If you choose to connect a SPYPOINT external 12 V battery (SPLB-22, or SPLB-10, sold separately) to your **FLEX-M, FLEX-PLUS, FLEX-DARK** or **FLEX G-36**, it will become the camera's primary power source. Once the 12 V is depleted, the camera will use the LIT-22 or AA batteries in the battery tray.



- For the **FLEX-S** and **FLEX-S-DARK**, the internal battery is the camera's primary power source. If you choose to connect a SPYPOINT external 12 V battery, the internal battery will be used first, then the 12 V, then the LIT-22 or AA batteries in the battery tray.



- In the double battery tray of the **FLEX-PLUS**, you can use any configuration of compatible batteries. Keep in mind that the camera does not use both battery trays simultaneously; it will use the lowest capacity batteries first, then switch to the batteries in the second tray, once the first has been depleted. The FLEX-PLUS will use rechargeable power sources (12 V, LIT-22) before AA. So, if you use an external 12 V battery, it will be used before any AAs or LIT-22s. If you use two sets of AA batteries or a set of LIT-22s in both trays, the set with the lowest capacity will be used first. If you use AA batteries in one tray and a LIT-22 in the other, the LIT-22 will be used first.

Please check the chart below to confirm compatibility for the double battery tray:

TRAY 1	AA	LIT-22	AA	LIT-22	ANY	NONE
TRAY 2	LIT-22	AA	AA	LIT-22	NONE	ANY

### HOW TO CHECK BATTERY LEVEL

- Once the device is powered ON. There are four green lights within the battery icon indicating the battery level.

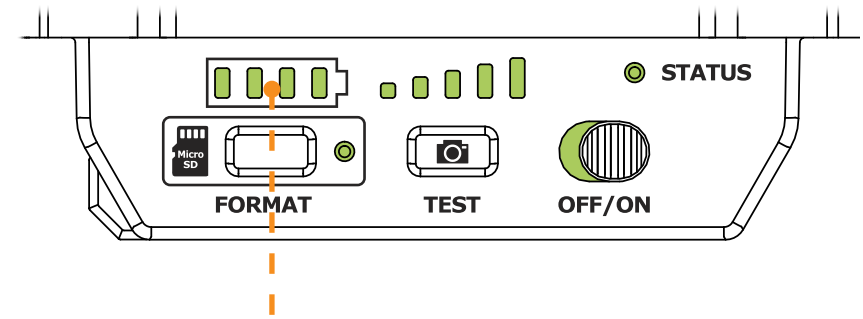

- On the SPYPOINT app: on the camera's page, you will see the battery charge level for each of your devices. You can access more details on the status of your battery by going to the status page. When you receive low battery alerts, we suggest that you change the batteries before they completely drain.



# MICROSD MEMORY CARD

A microSD memory card (with a maximum capacity of 512 GB, sold separately) is necessary for the camera's operation. It is used to save photos, videos, and other camera status files. Please note that all photos and videos in their original format are kept on the card. The files sent to your SPYPOINT app are lighter versions. You can retrieve the original versions at any time by removing the card from the camera and transferring the contents to another device, such as a computer.

**This table shows the approximate quantity of photos or videos that can be recorded and stored on the card according to its capacity:**

MEMORY	4 GB	16 GB	32 GB	128 GB	512 GB
PHOTOS (36 MP)	1 700	7 000	13 900	55 700	222 900
PHOTOS (28 MP)	2185	8 740	17 480	69 920	279 680
VIDEOS (1080P)	627	2 508	5 016	20 064	80 256
VIDEOS (720P)	941	3 764	7 528	30 112	120 448

## INSTALLATION

- Ensure the camera is turned OFF.
- Find the microSD card slot located at the bottom of the camera (see photo).
- Insert a microSD card (up to 512 GB) in the microSD card slot with the metal contacts facing up.
- The card is inserted correctly when a click is heard.

## PLEASE NOTE

FLEX series cameras are equipped with continuous mode. This means that when the memory card is full, the camera will continue to save new photos and videos by erasing the first recorded files.

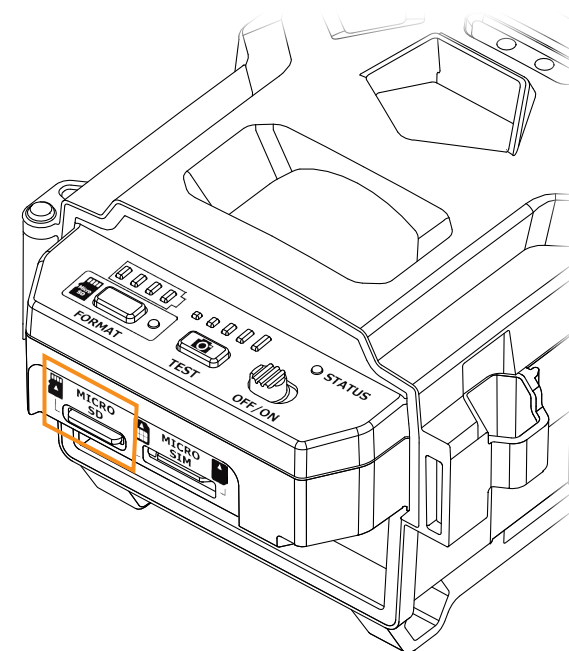

## FORMATTING

We recommend using the FORMAT button to quickly format the microSD card. This is required for cards 64 GB+ or if you want the camera to take photos and videos while transmitting.

1. Turn the camera ON.
2. Press and hold the FORMAT button for five seconds.
3. The microSD light will blink green while the card is formatting.
4. Once complete, the microSD light will become solid green.

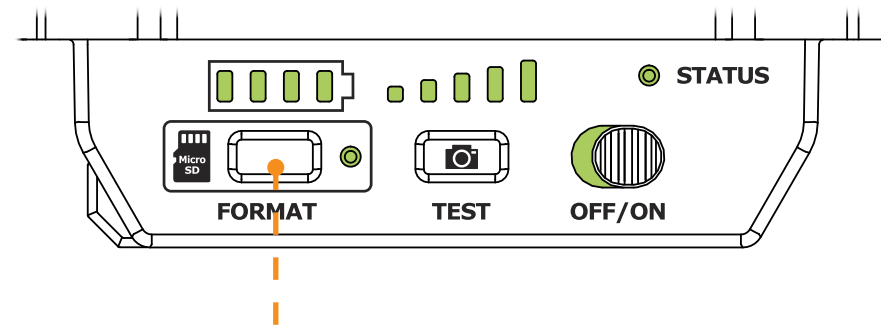

## REMOVAL

- Before removing the memory card, always turn your camera OFF to prevent files on the card from being deleted or damaged.
- To remove the card, push it lightly into the camera until you hear a click. Then slide it out of the device.

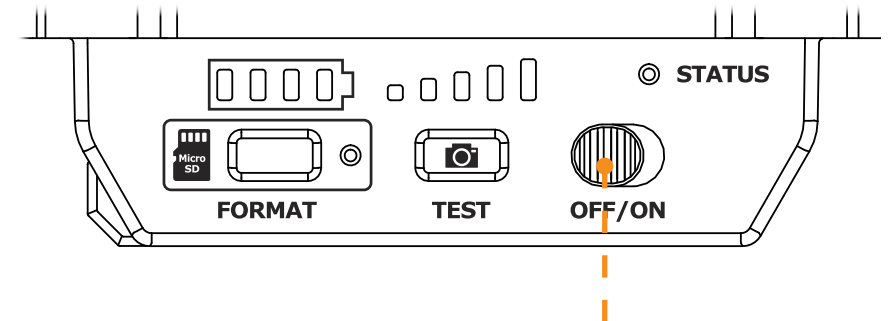

## TRANSFERRING FILES TO A COMPUTER

- Turn the camera OFF.
- Remove the microSD card from the camera.
- Insert the microSD card in the microSD computer slot or use an adapter for microSD cards.
- The computer will recognize the microSD card. There may be two different disk drives recognized, this is normal after use in the camera. See more detailed instructions below.
- If the computer doesn't detect the microSD card, this means it is corrupt and needs to be replaced.

## ON A PC

On your desktop, click on **"My Computer"** or **"This PC"**.

Locate your device under **"Removable Disk"** and click to access it. Then, click on **"DCIM"** and **"100DSCIM"** to find all saved photos and videos. If you do not see the photos or videos in the folder you checked, try again in the other **"Removable Disk"** folder.

Select the files you want to copy. With some Windows versions, the simplest way is to select them by clicking on the **"Home"** tab and choosing **"Select all"** on the right side. With some Windows versions, you can press on **"Ctrl"** and **"A"** or click on the **"Edit"** menu and choose **"Select all"**.

Click on the **"Copy"** icon on the left of the ribbon (or hold the **"Ctrl"** and **"C"** keys).

If you do not want to select all photos or videos, hold down the **"Ctrl"** key and click on the files you want to select before clicking on the **"Copy"** icon.

Access the folder where you want to save your photos and videos or create a new folder by clicking on the **"New folder"** button. (You can also click on **"Ctrl"**, **"Shift"**, and **"N"** to create a new folder, or right-click in a blank space in the **"Pictures"** folder and choose **"New"**, then, in the following menu, click on **"Folder"**.)

Enter a name for your new folder, click on **"Enter"**, then double-click on the folder to open it. In the **"Home"** tab, choose **"Paste"** (or click simultaneously on the **"Ctrl"** and **"V"** keys). The photos and videos will be copied in the new folder.

Once your photos and videos are transferred, click the **"Safely remove hardware and eject media"** button located in the task bar, then click **"Eject mass media storage device"**.

## ON A MAC

Click on the search tool in the **"Toolbar"**. Click the **"Go"** Tab, then select **"Computer"**.

Locate your device under the **"Locations"** tab and click to access it. Then click on **"DCIM"** and **"100DSCIM"** to find all saved photos and videos.

Click on **"Edit"** in the toolbar at the top of the screen, then click on **"Select all"** to highlight all individual files on the device. You can also access the **"Select all"** option by simultaneously clicking **"Cmd"** and **"A"**. If you don't want to import everything, you can highlight the desired photos or videos individually. Transfer photos and videos by clicking on **"Cmd"** and on the file name. Click on **"Edit again"** and then **"Copy"** (or **"Cmd"** and **"C"**) to copy the highlighted files.

Access the folder where you want to save your photos and videos, or create a new folder by right-clicking and pressing **"Cmd"** at the same time, then select **"New folder"** from the menu.

Click on **"Modify"**, then on **"Copy"** (or **"Cmd"** and **"V"**) to copy your chosen files in the selected folder. The photos and videos can take a few minutes to download, depending on the size and the number of the file you are importing.

Once your photos and videos are transferred, click on the **"Eject"** icon beside the name of your device, then unplug the device from your MAC.



## INSTALL THE ANTENNA

The antenna doesn't come installed. Please attach it to the camera as shown in the photo.

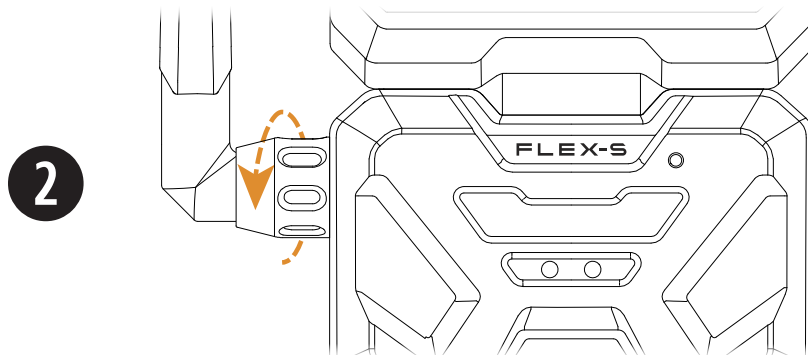
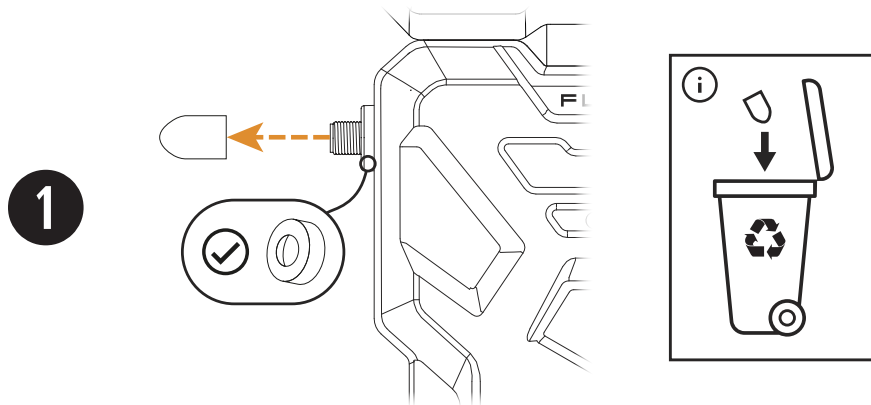

## FIND THE ACTIVATION CODE



Before you can use your camera, you must activate it.

To do so, locate the activation code inside your camera's battery compartment.

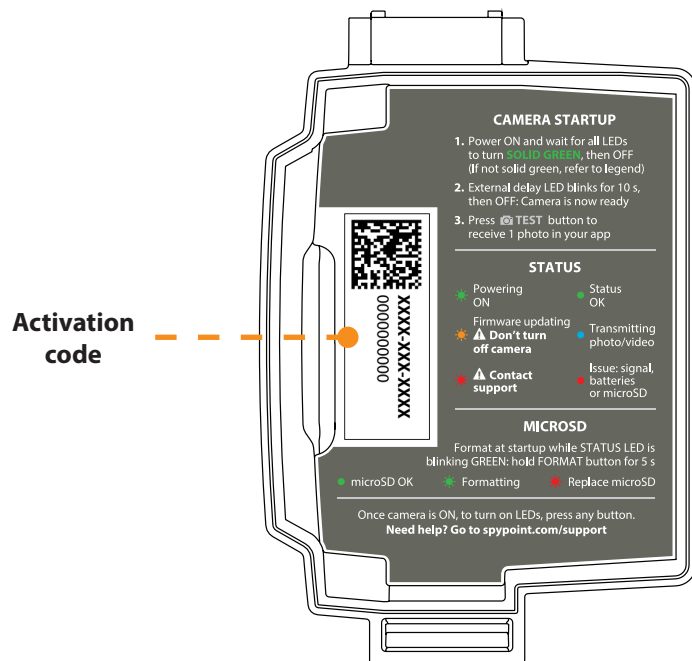

## CAMERA ACTIVATION FOR NEW USERS

1. On your mobile device or a computer, use the web browser and navigate to [www.spypoint.com](http://www.spypoint.com). At the top of your screen, select **"ACTIVATE A DEVICE"** link. Fill out the required fields and select **"SIGN UP"**.
2. Read and follow the on-screen steps carefully. Once you have done so – click **"READY TO START"**.
3. Select the camera model you are activating and then select **"CONTINUE"**.
4. Next, you will be prompted to enter the activation code. Enter the code found on your camera. Then you can personalize the device name and select how the device will be used.
5. Follow the on-screen instructions and turn on your device to verify signal strength - click **"NEXT"**.
6. On this screen, you can select a transmission plan or select **"SKIP FOR NOW"**. If you select **"SKIP FOR NOW"**, the camera will be placed on a free 100-photo per month plan.
7. After selecting a plan option and checking out or selecting the **"SKIP FOR NOW"** button - you are finished activating your device. You can select **"DONE"** or if you have another device to activate – select **"ADD ANOTHER"**.

### CAMERA ACTIVATION FOR EXISTING USERS ON THE SPYPOINT APP

1. On Google Play™ or the App Store™, search for **“SPYPOINT”**.
2. Download and install the SPYPOINT app on your smartphone or tablet.
3. Start the app. Select **“LOGIN”**. Enter your account information and select **“LOGIN”**.
4. Select the **“CAMERAS”** tab at the bottom of the screen and press the orange + button.
5. In the list, select your camera model, then follow the on-screen steps.
6. When complete, you will see the camera on the cameras page in your app.

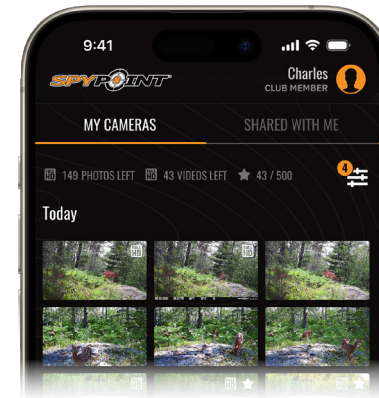

### CAMERA ACTIVATION FOR EXISTING USERS ON THE SPYPOINT WEBSITE

1. On the [www.spypoint.com](http://www.spypoint.com) website, select **“ACTIVATE A DEVICE”** at the top of the screen. On the displayed page, click **“LOGIN TO MY ACCOUNT”** and then input your account information. Continue by pressing the **“LOGIN”** button.
2. Select the + sign on the far right of the page; in the list, select your camera model then follow the steps.
3. When complete, you will see the device under My Cameras in your account.

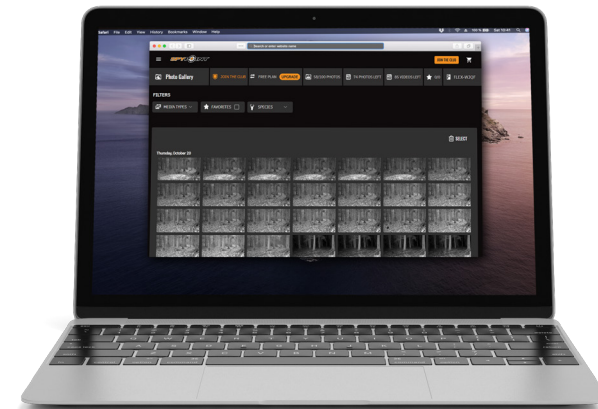

### CHOOSE A TRANSMISSION PLAN

All FLEX series cameras come with a FREE 100-photo per month transmission plan. To upgrade, choose the plan that best suits your needs by visiting <https://www.spypoint.com/en/spypoint-experience/plans>.

# FIELD INSTALLATION

## INSTALL THE CAMERA IN THE FIELD

1. To install the camera, loop the installation strap through the intended slots.
2. Choose a solid tree that does not move in the wind, as movement will cause false detections.
3. Make sure the area immediately in front of your camera is free of branches or twigs that could be blown into the camera's detection zone by the wind.
4. The camera should be at the same height of the animal's mid-body.
5. The targeted animal should be at 25 ft (7.5 m) away from the camera.
6. To produce brighter photos and videos at night, try including stationary items in the background (such as rocks or tree trunks) that reflect the camera's flash.

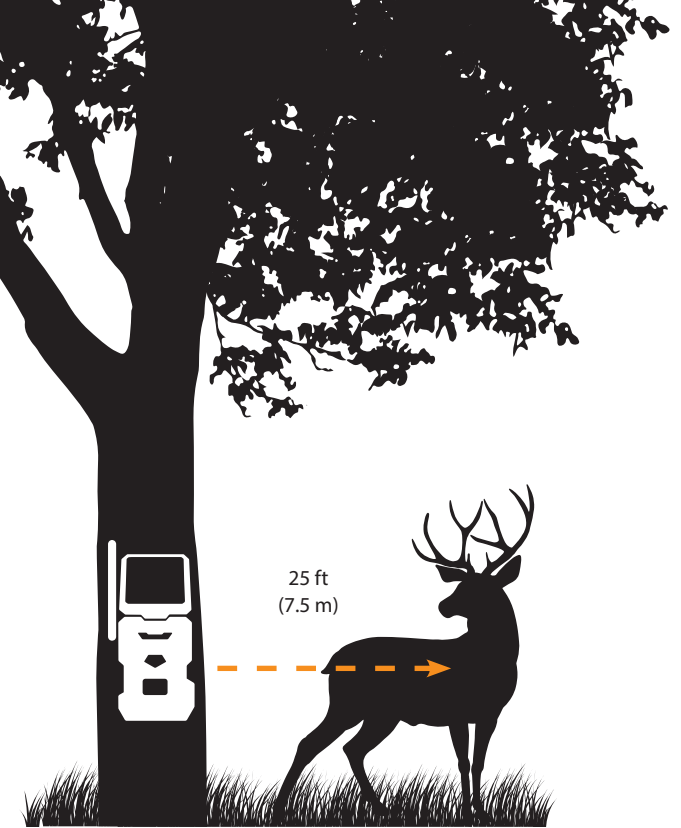

## START THE CAMERA

### BEFORE STARTING YOUR CAMERA, PLEASE ENSURE THAT:

- ✓ The antenna is installed.
- ✓ The internal battery is fully charged (FLEX-S and FLEX-S-DARK).
- ✓ The microSD card is formatted and inserted in the camera.
- ✓ The camera is activated.
- ✓ The camera is securely installed.



## INITIATE THE FIRST-TIME START-UP SEQUENCE

1. Turn the camera ON.
2. The green STATUS light will flash and the battery level will be displayed.
3. The signal lights will flash together until a signal is found. Once a signal is found, the number of bars will correspond to the signal strength.
4. The microSD card light will be ON.
5. The delay light will blink for 10 seconds, and the STATUS light will turn solid green.
6. All lights will turn OFF and the camera will go into standby mode – awaiting a trigger.

**Congratulations, your camera is ready to go! To verify that everything is working correctly, you can take a test photo.**

## TAKE A TEST PHOTO

After the camera has gone through the first-time start-up sequence, the TEST button can be used to take a single photo that will be sent to the app to ensure functionality. Please ensure all lights are OFF before proceeding. Please note that the test will not work if the camera is not on an active transmission plan with photos remaining or if it is busy with another task (synchronizing with the server, recording a photo/video, or running through the start-up sequence).

**Follow the steps below to take a test photo:**

1. Press the TEST button for at least one second.
2. The battery level will be displayed.
3. Signal lights will blink together every second until the camera connects to an available network. It will then display the number of lights corresponding to the signal strength.
4. Once the TEST photo has been captured, the camera's LED lights will turn blue. When they turn OFF, you will receive a photo on the app (timing based on the cellular signal strength of both the camera and your phone).

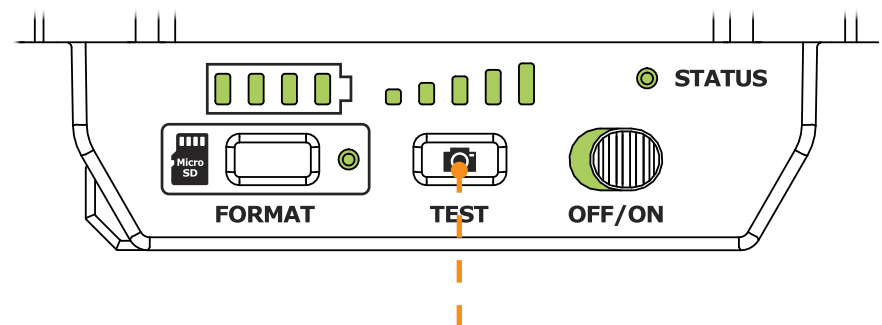
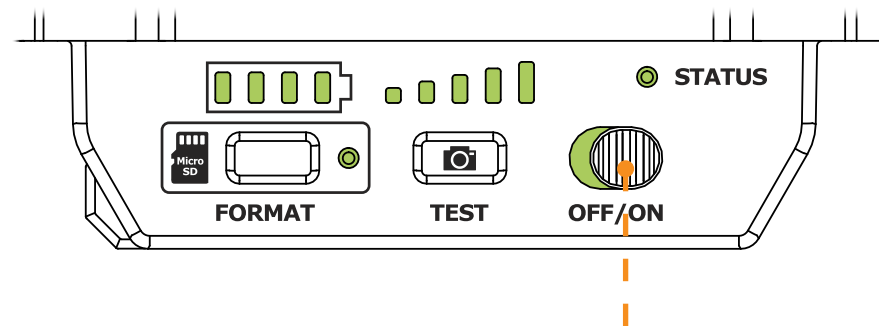

### MANAGE DEVICE

Use the SPYPOINT app to configure your camera settings.

<b>EDIT DEVICE NAME</b>	Allows you to name the camera for easy identification. This function is very useful for users with more than one camera.
<b>RESTORE FACTORY SETTINGS</b> Restore	Allows you to reset the camera to its default settings.

### IMAGE CAPTURE

<b>CAPTURE MODE</b> Photo; video; time-lapse; time-lapse+	<ul style="list-style-type: none"> <li>• <b>Photo:</b> The camera will capture photos when triggered by motion detection.</li> <li>• <b>Video:</b> The camera will capture video clips when triggered by motion detection.</li> <li>• <b>Time-lapse:</b> The camera will capture photos based on a schedule set by the user.</li> <li>• <b>Time-lapse+:</b> The camera will capture photos based on a schedule set by the user and when triggered by motion detection.</li> </ul>			
<b>MOTION DELAY</b> Instant; 10 s; 20 s; 30 s; 40 s; 50 s; 1 min; 3 min; 5 min; 10 min; 15 min; 20 min; 30 min; 1 h	Allows you to choose the period of time to wait before the camera detects again and records the next photo/video. A longer delay minimizes the number of photos and videos taken and therefore maximizes battery life. A shorter delay maximizes surveillance in the area but consumes more power. Shorter delays are recommended when the camera is used for security purposes.			
<b>MICROSD PHOTO RESOLUTION</b> Medium/high	Allows you to determine the quality of the photos saved on your microSD card.			
		<b>FLEX-PLUS, FLEX G-36, FLEX G-36C, FLEX-S</b>	<b>FLEX-M</b>	<b>FLEX-DARK, FLEX-S-DARK</b>
	<b>Medium</b>	2 MP	2 MP	2 MP
<b>High</b>	36 MP	28 MP	40 MP	
<b>MULTI-SHOT</b> 2; 3	Sets the camera to take 2 or 3 consecutive photos at each detection, with a 5-second delay between each photo.			
<b>SENSITIVITY</b> Low; normal; high	Allows you to choose the detection sensitivity of the device. A higher sensitivity allows you to detect movement in front of the camera more effectively, so the camera will take more pictures.			

## CELLULAR SETTINGS

<p><b>DAILY SYNC TIME</b></p>	<p>Allows you to choose the time when the camera will make its first sync of the day with the SPYPOINT app.</p> <p><b>Note:</b> The camera is configured by default to sync 6 times per day, starting from the time you activate the camera. For example, if the camera is activated at 1:42 p.m., this will be the time of the first sync. The next sync will be at 5:42 p.m.</p>
<p><b>SYNC FREQUENCY</b> 1; 2; 4; 6; 12; each detection</p>	<p>Allows you to choose the number of times the camera will sync with the SPYPOINT app each day.</p>
<p><b>CELLULAR</b> Activated/not activated</p>	<p>Allows you to activate or deactivate the cellular mode. Note that this setting will only take effect the next time the camera syncs.</p>
<p><b>TAKE A PHOTO/VIDEO AT EACH SYNC</b> Activated/not activated</p>	<p>During the next sync, the camera will automatically take a photo or a video and send it to the app.</p>

## CAMERA COMMANDS

<p><b>TAKE A PHOTO/VIDEO</b> FLEX-S, FLEX-S-DARK, and FLEX-PLUS only</p>	<p>Allows you to request a photo or video before the camera's next sync when the Operation Mode is set to Instant Mode.</p>
<p><b>UPDATE STATUS</b> FLEX-S, FLEX-S-DARK, and FLEX-PLUS only</p>	<p>Allows you to request a status update before the camera's next sync.</p>

## GENERAL

<b>DATE FORMAT</b> MM/DD/YYYY or DD/MM/YYYY	Allows you to choose the date format displayed.
<b>TIME FORMAT</b> 12 h or 24 h	Allows you to choose the time format displayed.
<b>BATTERY TYPE</b> Automatic or AA_LIT	Allows you to select the battery type installed in the camera.



## VERIFYING CAMERA STATUS

Three tools are available to help you check the status of your FLEX series camera and to inform you of any problems that may occur during its operation.

### 1. NOTIFICATIONS

The camera will send notifications to the SPYPOINT app to help you stay informed of its status. You may receive a notification when:

- You get a photo or video from your camera.
- You forget to insert a microSD card in your camera.
- The microSD card you used is not compatible with your camera.
- The camera's battery power is getting low.

### 2. STATUS PAGE

The following are explanations of the indicators on your camera's status page in the SPYPOINT app. Please note, each status indicator is updated when the camera syncs. Therefore, what appears reflects the camera's status at the time of its last communication.

GENERAL INFORMATION	
<b>SIGNAL</b> Strength of the cellular signal	1 - 5 bars
<b>BATTERY</b> Battery percentage remaining	0 - 100% (AA/LIT-22/12 V)
<b>LAST COMMUNICATION</b> The date and time of the last device transfer	Date and time
<b>TEMPERATURE</b>	°C or °F
<b>CAMERA ACTIVATION</b>	Date and time

FIRMWARE	
<b>FIRMWARE VERSION</b> Displays the firmware version	X.X.X-XX-XXXXXXXXXX







LOCATION	
<b>GPS COORDINATES</b> GPS	XX.XXXXXX, XX.XXXXXX

STORAGE	
<b>SD CARD</b> Used space	X.XGB / XX.XGB

CAMERA SHARING	
<b>NUMBER OF GUESTS</b> The number of users the camera gallery is being shared with. This feature is only available with membership to the Insiders Club.	#

DEVICE INFORMATION	
<b>MODEL</b>	FLEX series
<b>ACTIVATION CODE</b> This is the code that allowed you to add this camera to your SPYPOINT account. Share it carefully.	XXXX-XXX-XXXX

PLEASE NOTE: THE CAMERA IS READY AND ACTIVE WHEN ALL THE LIGHTS ARE OFF.

STATUS LED COLOR	PATTERN	INDICATION
 Green	Solid	The camera has been triggered and is taking a photo or video
 Blue	Solid	A photo or video is being transmitted
 Blue	Blinking each second until the reset is complete	Factory reset
 Orange	Blinking each second for 30 seconds	Firmware update
 Red	Solid (does not go OFF)	No signal detected
 Red	Slow blinking (every 2 seconds)	SIM issue/Critical hardware failure

# OFFERED ACCESSORIES



## LITHIUM BATTERY SOLAR PANEL

Compatible with all SPYPOINT devices with a 12 V socket. DC power adapter, mounting bracket and installation strap included.

#SPLB-22



## COMPACT LITHIUM BATTERY SOLAR PANEL

Compatible with all SPYPOINT devices with a 12 V socket. DC power adapter, mounting bracket and installation strap included.

#SPLB-10



## RECHARGEABLE LITHIUM BATTERY PACK

Rechargeable lithium battery pack and charging cable included. 7.4 voltage.

#LIT-22



## FLEX SERIES CAMERA STEEL SECURITY BOX\*

Fits the SPYPOINT FLEX Series camera (excluding FLEX-PLUS).

#SB-500S



## ADJUSTABLE MOUNTING ARM

Fits any camera with a standard 1/4"-20 screw-in tripod mount.

#MA-500



## LONG RANGE CELLULAR ANTENNA

Boosts the cellular signal. 15 ft (4.57 m) cable. No external power source necessary.

#CA-01



## CABLE LOCK

6 ft (4.57 m) cable lock compatible with all cameras and security boxes from SPYPOINT.

#CLM-6FT



## 32 GB MICROSD CARD

High-speed, class 10, 32 GB microSD card with adapter. 10-year warranty.

#MICRO-SD-32GB

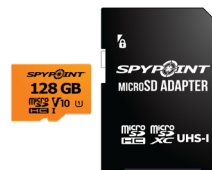

## 128 GB MICROSD CARD

High-speed, class 10, 128 GB microSD card with adapter. 10-year warranty.

#MICRO-SD-128GB

For more information about other available accessories, go to [www.spypoint.com](http://www.spypoint.com).

\*Steel boxes may affect wireless connectivity, especially in low-reception areas.

ISSUES	POSSIBLE SOLUTIONS
<p><b>MY CAMERA DOESN'T TURN ON.</b></p>	<ol style="list-style-type: none"> <li>1. Check your power source is fully charged.</li> <li>2. <b>FLEX-S and FLEX-S DARK only:</b> charge the camera with the 12 V to USB-A cable for 24 hours.</li> <li>3. If using AA batteries, check the level of each battery with a meter. Make sure they are fully inserted and follow the polarity chart printed on the tray.</li> <li>4. Slide the power switch to OFF and then back to ON.</li> <li>5. Try another power source.</li> </ol>
<p><b>MY CAMERA'S SIGNAL STRENGTH IS WEAK.</b></p>	<ol style="list-style-type: none"> <li>1. Check that the antenna is properly secured.</li> <li>2. Move the camera to a higher spot that is free of obstacles. Avoid deep valleys, dense foliage, metal and concrete structures.</li> <li>3. Check the signal at the new location. Press the TEST button to refresh the signal lights on the camera.</li> <li>4. Install the SPYPOINT CA-01 long-range antenna up to 15 ft above the camera to improve reception.</li> <li>5. <b>IMPORTANT:</b> always test your camera before leaving the area. Move in front of the camera and check the app for a new photo.</li> </ol>

ISSUES	POSSIBLE SOLUTIONS
<p><b>MY CAMERA STOPPED COMMUNICATING.</b></p>	<ol style="list-style-type: none"> <li>1. Check the battery level and change the power source, if necessary.</li> <li>2. Check the daily sync time in your camera settings. Your camera should communicate at least once every 24 h.</li> <li>3. Ensure the camera is running the latest firmware by checking the camera's status page in the SPYPOINT app. If the firmware version doesn't match the one on the model's online support page contact SPYPOINT customer support or download the firmware update on <a href="http://www.spypoint.com/en/support">www.spypoint.com/en/support</a> and copy it to a microSD card. Please note that most cameras automatically update their firmware if they communicate with SPYPOINT servers.</li> <li>4. After 48 h without communicating, we recommend you inspect the camera. Bring fresh batteries and a new microSD card (equipped with the latest firmware, if necessary). At each step, test your camera:             <ol style="list-style-type: none"> <li>a. Check the antenna.</li> <li>b. Slide the power switch to OFF then back to ON.</li> <li>c. Turn OFF the camera and replace the power source.</li> <li>d. <b>If firmware is up to date:</b> Turn OFF the camera and insert a new microSD card. Turn ON the camera and immediately press "FORMAT" for 5 seconds. The FORMAT light turns OFF once the operation is done.</li> <li>e. <b>If firmware is not up to date:</b> Turn OFF the camera and insert the microSD card on which you installed the latest firmware. Turn ON the camera. It is ready to take photos when all the lights are OFF.</li> </ol> </li> </ol>
<p><b>MY CAMERA TAKES TOO MANY PHOTOS.</b></p>	<ol style="list-style-type: none"> <li>1. Go to the camera settings in the SPYPOINT app.</li> <li>2. Check the sensitivity level and switch it to "LOW".</li> <li>3. Adjust the delay if animals tend to linger in the area (i.e. feeder, corn field, pond).</li> <li>4. Make sure tall grass, branches, foliage, and other moving objects do not trigger the camera unnecessarily.</li> <li>5. Check the direction of the camera is not causing light or sunbursts to falsely trigger captures. Ensure your camera is in a north/south orientation.</li> </ol>

## LIMITED WARRANTY

This SPYPOINT product is covered by a two-year warranty that covers parts and workmanship from the purchase date. The original proof of purchase must be presented to confirm that the warranty is applicable. This warranty will be honored only in the country of the original purchase.

### THIS WARRANTY DOES NOT APPLY TO:

- Consumable parts, including but not limited to batteries, the performance of which is known to decrease over time.
- Damages caused by improper use of the device, use of the device with another product, negligence, accidents, contact with liquid, fires, earthquakes, or any other type of external causes.
- SPYPOINT products bought online from an unauthorized retailer.
- Products that were modified or altered.
- Aesthetic damage, including but not limited to scratches or plastic breakage.
- Damages caused by the usage of a product outside of the SPYPOINT recommendations.

## FCC STATEMENT

Changes or modifications not expressly approved by the party responsible for compliance could void the user's authority to operate the equipment.

This equipment has been tested and found to comply with the limits for a Class B digital device, pursuant to Part 15 of the FCC Rules. These limits are designed to provide reasonable protection against harmful interference in a residential installation. This equipment generates uses and can radiate radio frequency energy and, if not installed and used in accordance with the instructions, may cause harmful interference to radio communications. However, there is no guarantee that interference will not occur in a particular installation. If this equipment does cause harmful interference to radio or television reception, which can be determined by turning the equipment off and on, the user is encouraged to try to correct the interference by one or more of the following measures:

- Reorient or relocate the receiving antenna.
- Increase the separation between the equipment and receiver.
- Connect the equipment into an outlet on a circuit different from that to which the receiver is connected.
- Consult the dealer or an experienced radio/TV technician for help.

**This device complies with part 15 of the FCC rules.  
Operation is subject to the following two conditions:**

1. This device may not cause harmful interference.
2. This device must accept any interference received, including interference that may cause undesired operation.



## CE STATEMENT

Hereby, SPYPOINT declares that this FLEX series trail camera model is in compliance with the essential requirements and other relevant provisions of Directive 2014/53/EU. In accordance with Article 10(2) and Article 10(10), this product is allowed to be used in all EU member states.

Use the FLEX series in an environment with the temperature between -1°C and 35°C.



## IC STATEMENT

This device complies with Industry Canada's licence-exempt RSSs. Operation is subject to the following two conditions:

1. This device may not cause interference.
2. This device must accept any interference, including interference that may cause undesired operation of the device.

The term "IC:" before the certification/registration number only signifies that the Industry Canada technical specifications were met. This product meets the applicable Industry Canada technical specifications.



## FREQUENCY

### DETAILS ON THE FREQUENCY RANGES OF THE RADIO TECHNOLOGIES USED AS WELL AS THE MAXIMUM TRANSMISSION POWER IN THIS FREQUENCY RANGE

Frequency ranges of the technologies used:	Maximum transmission power in this frequency range:
<b>LTE</b>	
<b>Uplink:</b>	
E-UTRA Band 1: 1920 MHz - 1980 MHz	0.32 W
E-UTRA Band 3: 1710 MHz - 1785 MHz	0.32 W
E-UTRA Band 7: 2500 MHz - 2570 MHz	0.32 W
E-UTRA Band 8: 880 MHz - 915 MHz	0.32 W
E-UTRA Band 20: 832 MHz - 862 MHz	0.32 W
E-UTRA Band 28: 703 MHz - 748 MHz	0.32 W
<b>Downlink:</b>	
E-UTRA Band 1: 2110 MHz - 2170 MHz	—
E-UTRA Band 3: 1805 MHz - 1880 MHz	—
E-UTRA Band 7: 2620 MHz - 2690 MHz	—
E-UTRA Band 8: 925 MHz - 960 MHz	—
E-UTRA Band 20: 791 MHz - 821 MHz	—
E-UTRA Band 28: 758 MHz - 803 MHz	—
<b>2G</b>	
<b>Uplink:</b>	
GSM 900: 880 MHz - 915 MHz	0.4 W
DCS 1800: 1710 MHz - 1785 MHz	0.2 W
<b>Downlink:</b>	
GSM 900: 925 MHz - 960 MHz	—
DCS 1800: 1805 MHz - 1880 MHz	—
<b>3G</b>	
<b>Uplink:</b>	
WCDMA Band I: 1920 MHz - 1980 MHz	0.32 W
WCDMA Band VIII: 880 MHz - 915 MHz	0.32 W
<b>Downlink:</b>	
WCDMA Band I: 2110 MHz - 2170 MHz	—
WCDMA Band VIII: 925 MHz - 960 MHz	—

# DISPOSAL

## ONLY USE ORIGINAL SPARE PARTS AND ACCESSORIES.

If your camera has been used so intensively that it must be replaced, or if you no longer have use for it, it is necessary to dispose of it at a recycling center.

Information on return points for your electrical appliance can be obtained from your local waste disposal company or from your local administrative offices.

Electrical appliances not only contain valuable recyclable raw materials, but also substances which, if disposed of improperly, can affect public health and the environment. Help ensure that valuable raw materials are recycled by returning your old appliance to a central collection point.

The WEEE (Waste Electrical and Electronic Equipment Directive) symbol represents the obligation for the labeled camera to be sent to a separate center for the proper recycling of electrical and electronic equipment.



Natural Resources  
Canada

Ressources naturelles  
Canada

### SPYPOINT FLEX Series

12 V DC • LIT-22 Lithium battery pack • 8 X R6 batteries (AA, 2 X 6 V)

Contain FCC ID: XMR201807EG91NA

IC: FLEX-M • 31724-FLEXM      FLEX G-36/FLEX-S • 10224A-2018EG91NA

FLEX G-36C • 31724-FLEXG36C      FLEX-PLUS • 31724-FLEXPLUS

FLEX-DARK • 31724-FLEXDARK      FLEX-S-DARK • 31724-FLEXSDARK

SPYPOINT 330 de la Jacques-Cartier Victoriaville QC G6T 1Y3 • Canada

3000 Gannett Avenue, Des Moines IA 50321 • United States (security@spypoint.com)

EUROHUNT GmbH Harzblick 25,99768, Harztor OT Ilfeld • Germany (info@eurohunt.de)

Thomas Jacks Limited Apex House, Timothy's Bridge Road

Stratford-upon-Avon, Warwickshire CV37 9BF • UK (info@thomasjacks.co.uk)